

U.S. Des. Pat. No. D781,677

This base converts a rotary tool into a miniature plunge router for fine detail work, allowing precise depth control for hardware and inlay recesses, or even freehand routing. Its low-slung grips and 4" x 3" footprint make it easy to position on narrow surfaces and close to edges. Made largely from aluminum with stainless-steel rods and knobs, it fits onto the 3/4-12 threaded collar found on most rotary tools (including most full-sized Dremel® tools).

Installation

Install the rotary tool in the plunge base through the housing threads* at the nose of the rotary tool (see **Figure 2**).

Fully screw the rotary tool into the threaded hole in the bridge so that it is firmly seated.

**Note: You may need to remove the rotary tool housing cap to expose the threads.*

If the orientation of the rotary tool (direction of the power switch) is not ideal, you can use the included shims to adjust it. The blue shim (0.010" thick) alters the orientation by approximately 45° and the black shim (0.020" thick) by 90°. The shims may be used in combination to achieve the desired orientation.

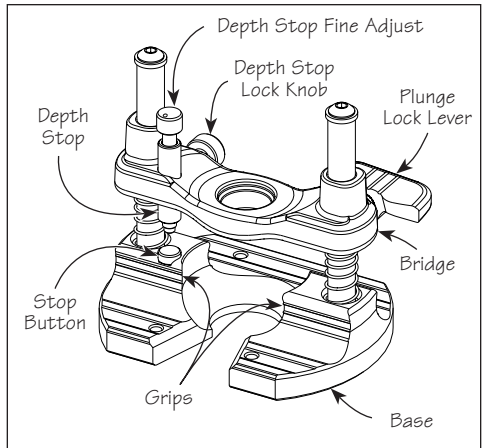

Figure 1: Rotary tool plunge base.

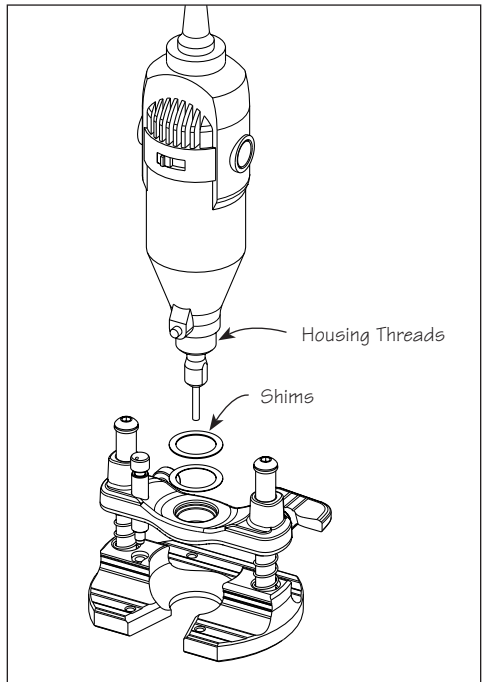

Figure 2: Rotary tool installation.

Plunge Action

The plunge lock lever controls the plunge action. When the plunge lock lever is released, the springs will automatically raise the bridge. Lower the bridge to the required setting and secure in position with the plunge lock lever.

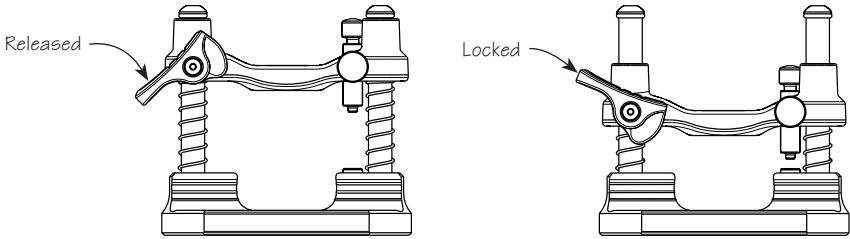

Figure 3: Plunge action.

Depth of Cut

Begin by “zeroing” the depth of cut. Release the plunge lock lever, lower the bridge and the rotary tool until the cutter just touches the work, and lock the bridge in position. Loosen the lock knob and position the depth stop so it contacts the stop button, and then secure with the lock knob. This gives you a starting point or “zero” position for your depth of cut.

To set the depth of cut, loosen the lock knob, raise the depth stop to desired depth of cut, and secure with the lock knob. Make a test cut in a scrap piece of wood. Release the plunge lock lever and lower the bridge until the depth stop contacts the stop button. Verify the setting and adjust as necessary.

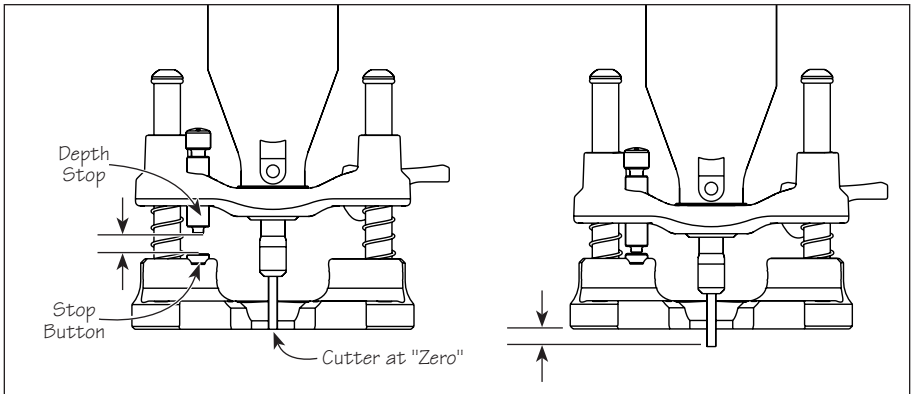

Figure 4: Depth of cut.

Tip: The ideal method for setting the required depth of cut is referentially by using the piece being installed (inlay, hardware, etc.) as a spacer. Starting from the “zero” position, release the depth stop, place the piece on the stop button, lower the stop until it contacts the material, and lock the stop in position. The resulting cut will now be equal in depth to the thickness of the material.

The depth stop fine adjust allows you to refine the depth of cut, such as when you would like the inlay slightly proud of the surface, or the hardware installed slightly below it. The fine screw changes the depth by 0.010” per half turn. Lowering the screw decreases the depth of cut, and raising the screw increases it.

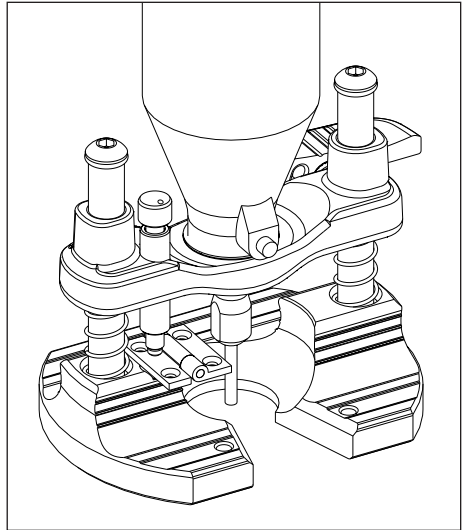

Figure 5: Referential depth of cut.

Accessories

- 05J65.03** Fence and Center Kit
- 05J65.05** Precision Adjuster
- 05N29.06** 12" Fence Rods, pr.
- 05J65.08** Template Bushings and Base Plate
- 05J65.09** 6" Traveller
- 05J65.10** 1" Inlay Bushings
- 05J65.11** LED Task Light